

accent
CEILINGS AND WALLS
A DIVISION OF ADAMS CAMPBELL COMPANY
ISO 9001: 2000 CERTIFIED

"ENVIROWOOD" METAL ZEE TRACK MOUNTED WALL PANEL SYSTEM (AC-730)

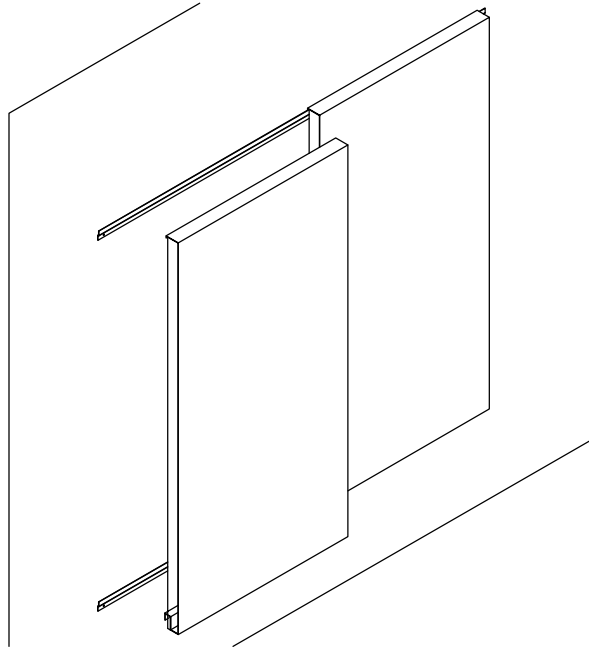

- Description:** Zee track mounted wall panels. Factory formed metal panels with formed edges all four sides (1.00", 2.00", 3.00" and 4.00" thick available), Perforated or Non-Perforated. Panels are mounted to concealed zee track mounted to wall or ridged backer. Perimeter trim available for field cut conditions.
- Application:** Wall panel provided for interior installation. Curved application available.
- Material:** Aluminum / Vinyl Veneer
- Finishes:** Standard simulated wood grain veneers include Maple, Oak and Cherry Reference Options tab for additional finishes available.
- Standard Sizes:** Maximum size 4'-0" x 10'-0"
- Fire Rating:** Class A
- Acoustics:** NRC rating of .70 to .100 can be achieved by selecting correct perforation pattern and acoustical backing.
- Perforation:** Reference Options Tab for Patterns, consult manufacturer for acoustical values
- Recycled content:** Aluminum 60% · Steel 33% · Stainless Steel 69%

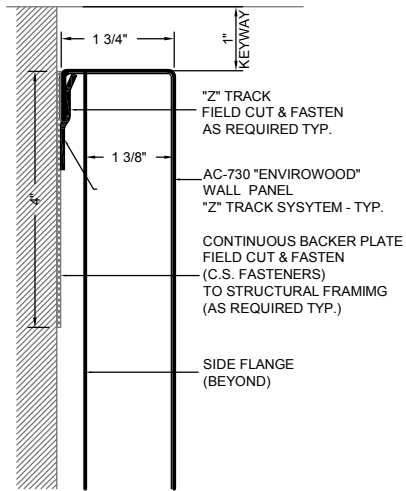

1 PERIMETER DETAIL (TOP)
AC-730-FT1

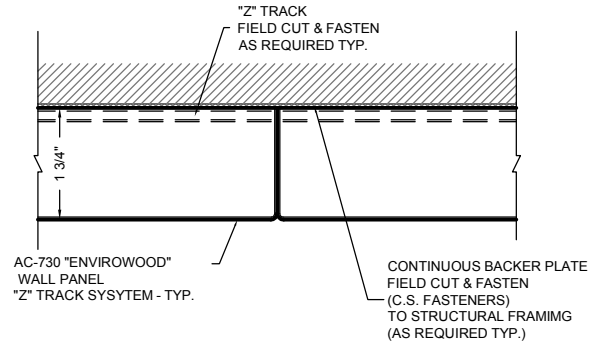

2 PANEL JOINT DETAIL
AC-730-FS1

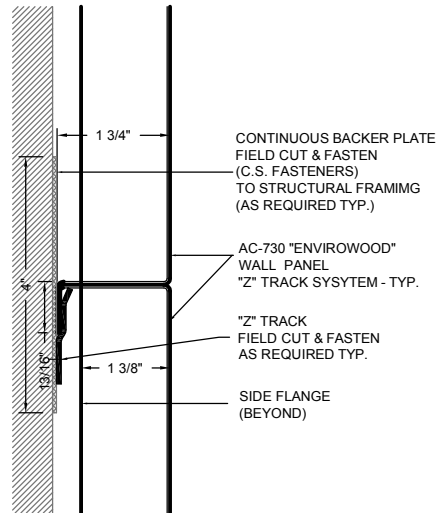

3 PANEL JOINT DETAIL
AC-730-FM1

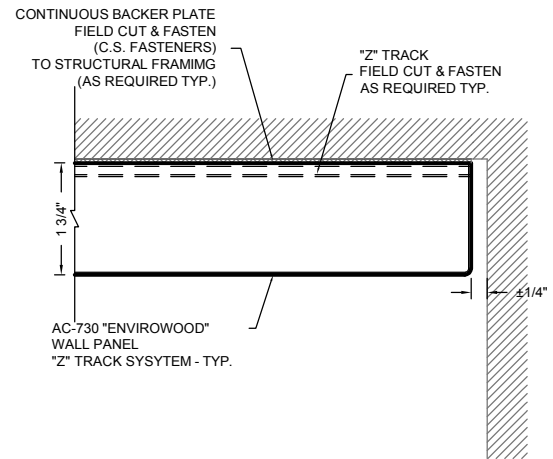

4 PERIMETER DETAIL (EDGE)
AC-730-FE1

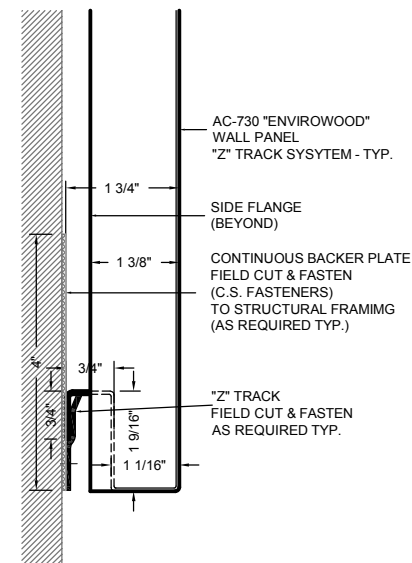

5 PERIMETER DETAIL (BASE)
AC-730-FB1

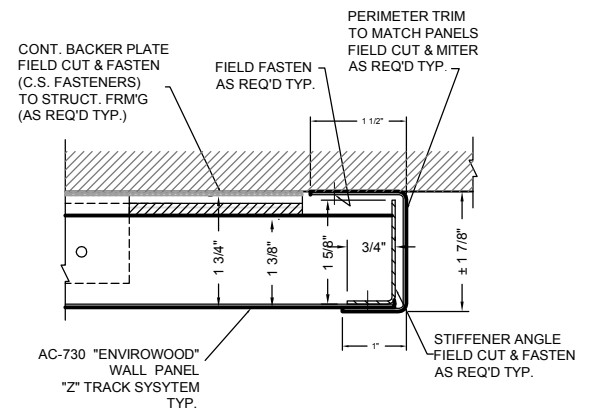

6 PERIMETER DETAIL
AC-730-FCE1

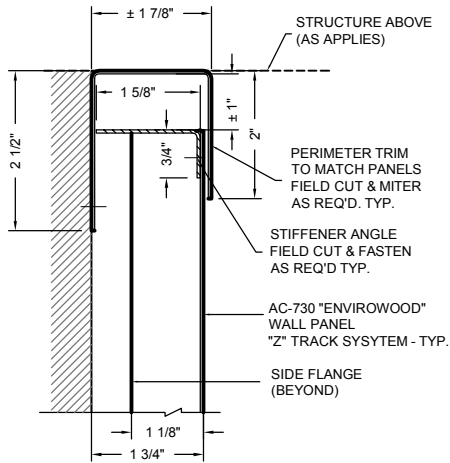

1 PERIMETER DETAIL (TOP)
AC-730-FCT1

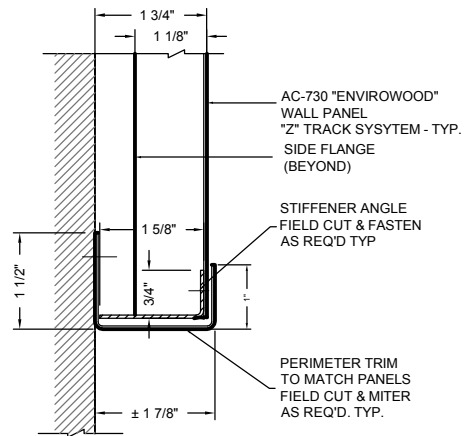

2 PERIMETER DETAIL (BASE)
AC-730-FCB1