

METAL ZEE TRACK MOUNTED WALL PANEL SYSTEM (AC-720)

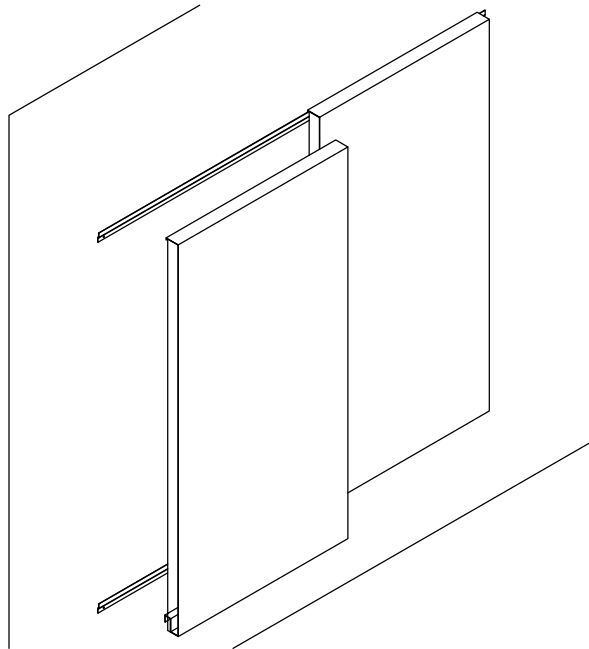

- Description:** Zee track mounted wall panels. Factory formed metal panels with formed edges all four sides (1.00", 2.00", 3.00" and 4.00" thick available), Perforated or Non-Perforated. Panels are mounted to concealed zee track mounted to wall or ridged backer. Perimeter trim available for field cut conditions.
- Application:** Wall panel provided for interior installation. Curved application available.
- Material:** Panel available in aluminum, steel or stainless steel
- Finishes:** Painted powder coat colors, brushed, bright, anodized, vinyl or custom finishes Reference Options tab for available finishes.
- Standard Sizes:** Maximum size 4'-0" x 10'-0"
- Fire Rating:** Class A
- Acoustics:** NCR rating of .70 to .100 can be achieved by selecting correct perforation pattern and acoustical backing.
- Perforation:** Reference Options Tab for Patterns, consult manufacturer for acoustical values
- Recycled content:** Aluminum 60% · Steel 33% · Stainless Steel 69%

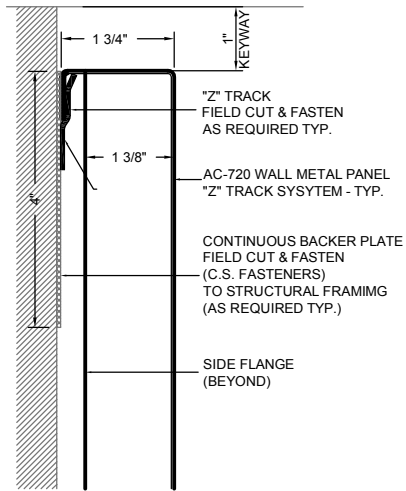

1 PERIMETER DETAIL (TOP)
AC-720-FT1

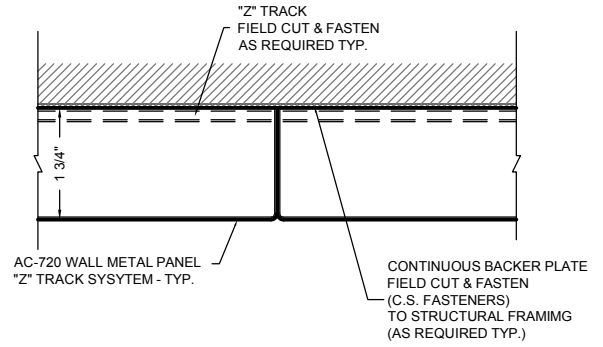

2 PANEL JOINT DETAIL
AC-720-FS1

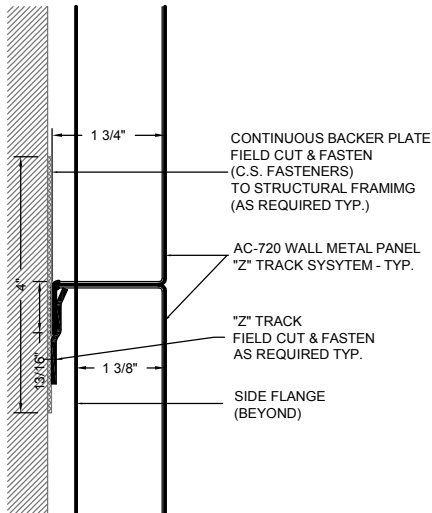

3 PANEL JOINT DETAIL
AC-720-FM1

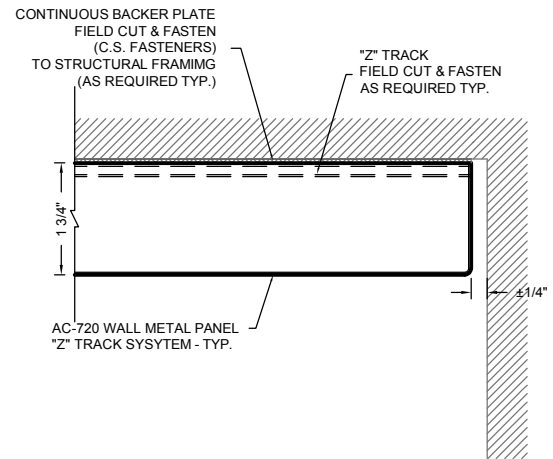

4 PERIMETER DETAIL (EDGE)
AC-720-FE1

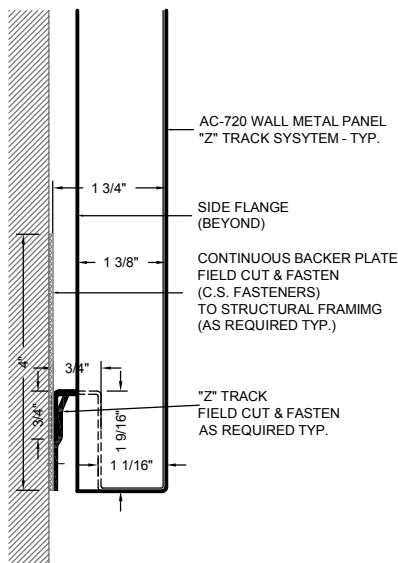

5 PERIMETER DETAIL (BASE)
AC-720-FB1

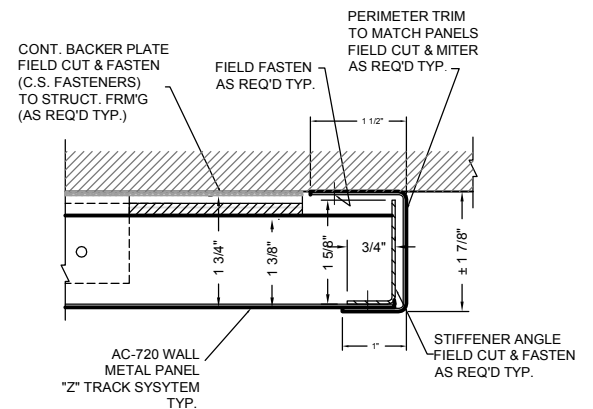

6 PERIMETER DETAIL
AC-720-FCE1

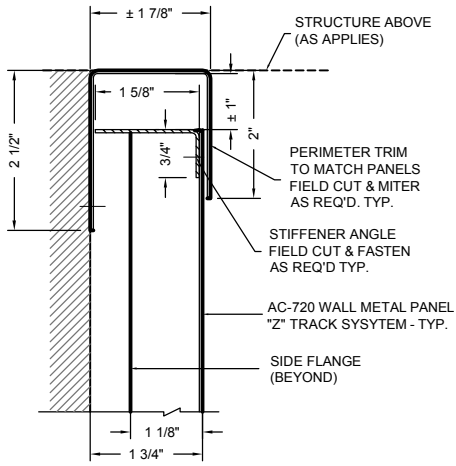

1 PERIMETER DETAIL (TOP)
AC-720-FCT1

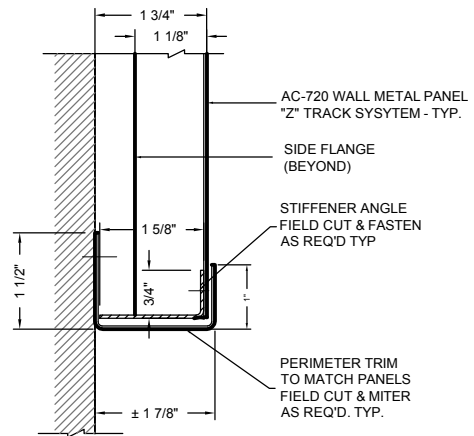

2 PERIMETER DETAIL (BASE)
AC-720-FCB1