

accent
CEILINGS AND WALLS
A DIVISION OF ADAMS CAMPBELL COMPANY
ISO 9001: 2000 CERTIFIED

TORSION SPRING MOUNTED CEILING SYSTEM (SureWood AC-440C)

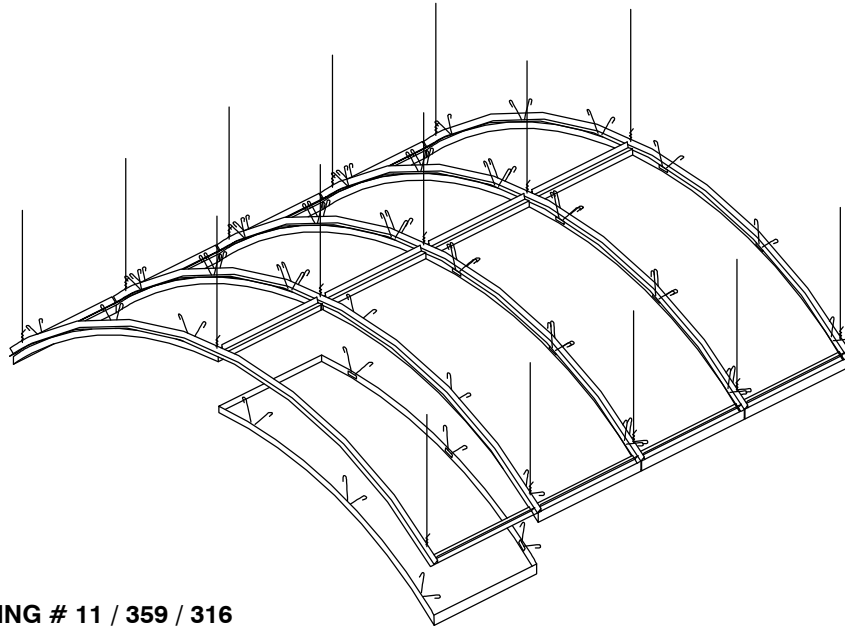

PATENT PENDING # 11 / 359 / 316

- Description:** Real wood veneer facing eliminates cost and warping issues of a real wood ceiling panel. Concealed torsion spring mounting system creates a clean monolithic appearance. A 1/16" wide reveal condition at all panel joints, Perforated or Non-Perforated. Concealed heavy-duty tee bar grid system supports each panel. Each individual panel can be removed without disturbing adjacent panels.
- Application:** Ceiling provided for a curved interior installation. (See AC-440F for flat application)
- Material:** Panels are aluminum with real wood facing laminated to face of panel.
- Finishes:** Real wood veneer facing include Maple, Birch, Ash, Cherry and Oak
Reference Options tab for additional finishes available.
- Standard Sizes:** 24" x 24", 24" x 48", 30" x 30", 36" x 36", 36" x 60", 30' x 72", 30" x 96" and 48" x 48". Custom sized and shaped panels also available.
- Fire Rating:** Class A
- Acoustics:** NCR rating of .70 to .100 can be achieved by selecting correct perforation pattern and acoustical backing.
- Perforation:** Reference Options Tab for Patterns, consult manufacturer for acoustical values
- Recycled content:** Aluminum 60% · Steel 33% · Stainless Steel 69%

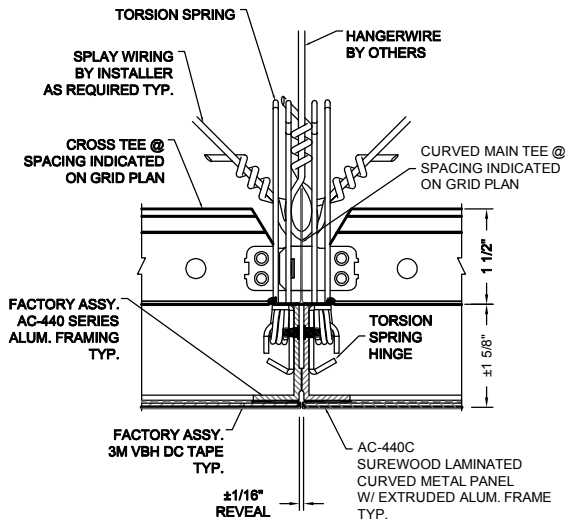

1 PANEL JOINT DETAIL
AC-440C-PJ1

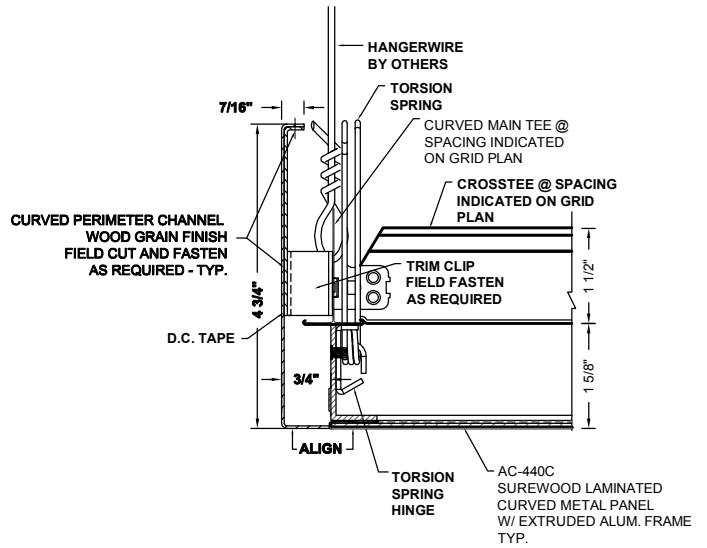

2 PERIMETER DETAIL
AC-440C-P1

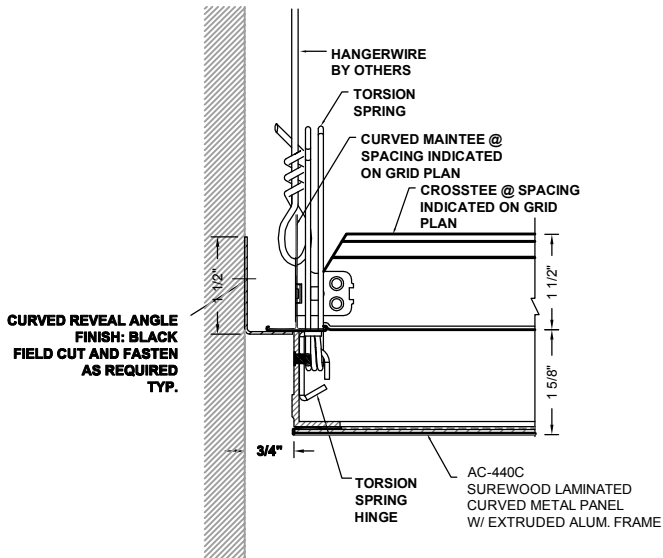

3 PERIMETER DETAIL
AC-440C-P2

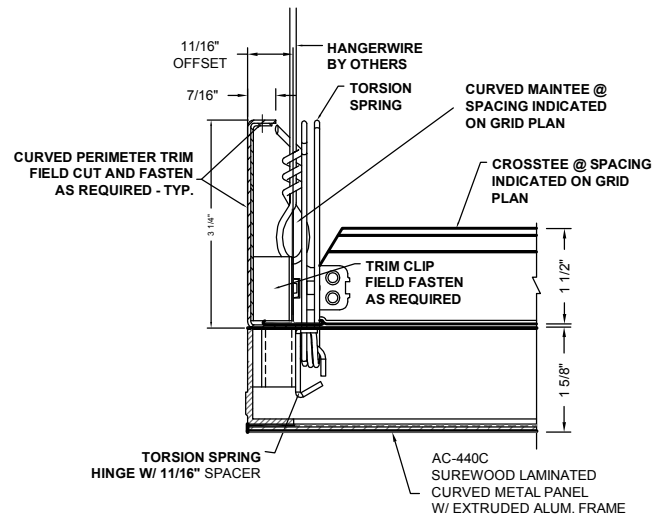

4 PERIMETER DETAIL
AC-440C-P3

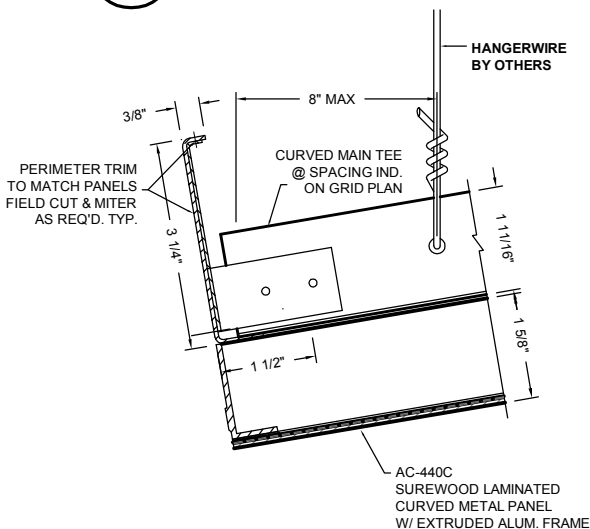

5 PERIMETER DETAIL
AC-440C-P4

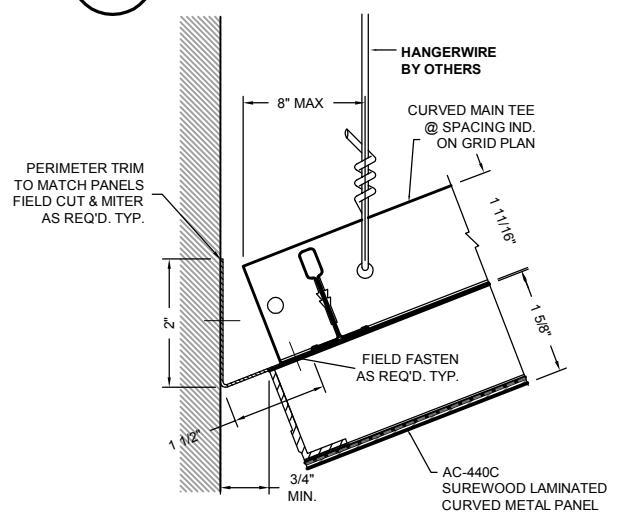

6 PERIMETER DETAIL
AC-440C-P5

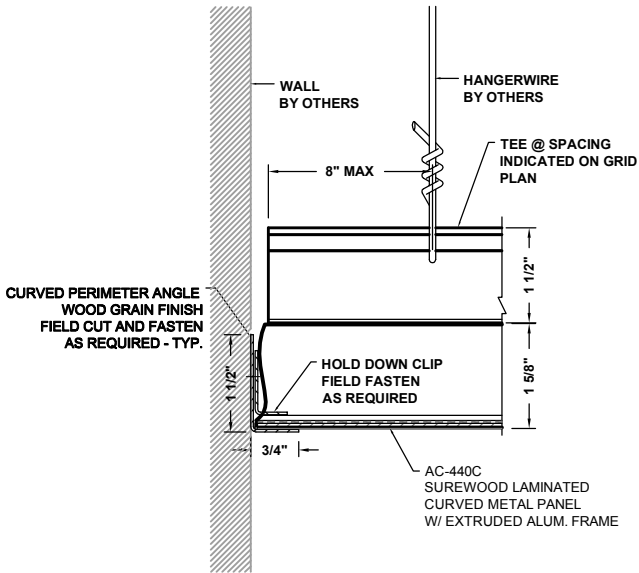

1 PERIMETER DETAIL
AC-440C-PFC1

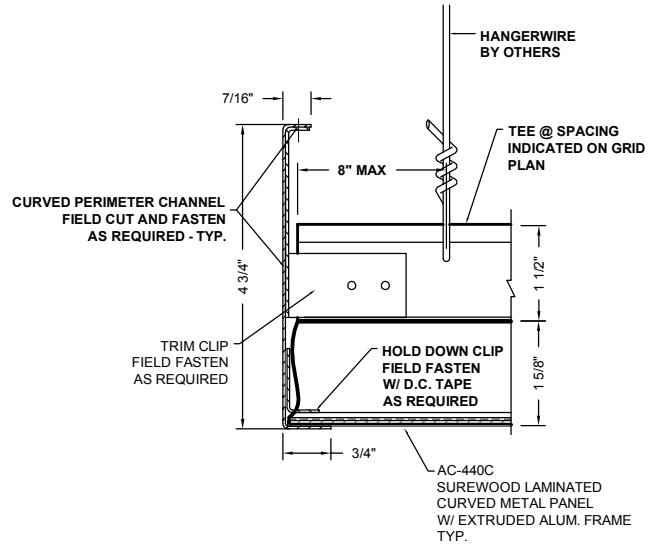

2 PERIMETER DETAIL
AC-440C-PFC2

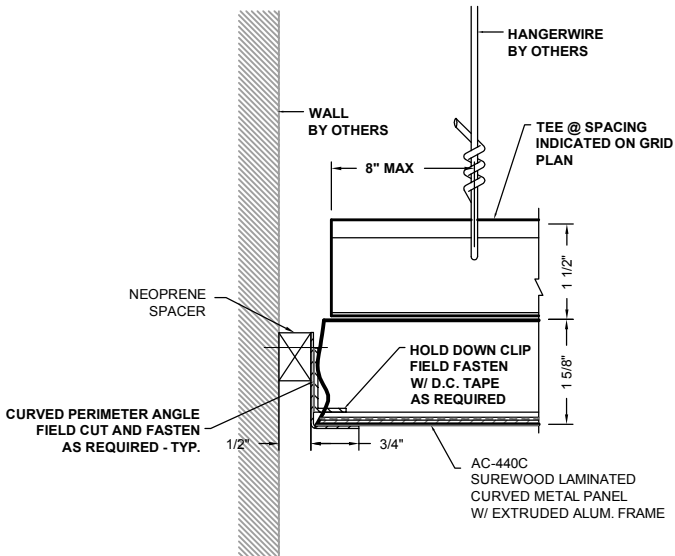

3 PERIMETER DETAIL
AC-440C-PFC3

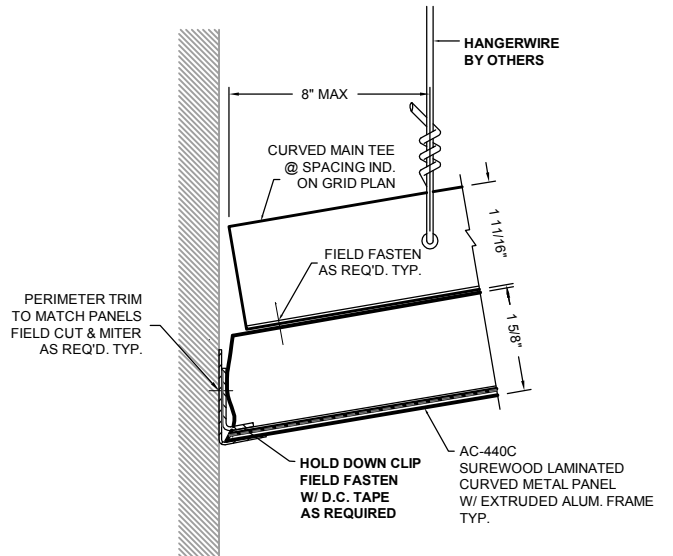

4 PERIMETER DETAIL
AC-440C-PFC4