

# accent

## CEILING AND WALLS

A DIVISION OF ADAMS CAMPBELL COMPANY  
ISO 9001: 2000 CERTIFIED

### TORSION SPRING MOUNTED CEILING SYSTEM (AC-410C)

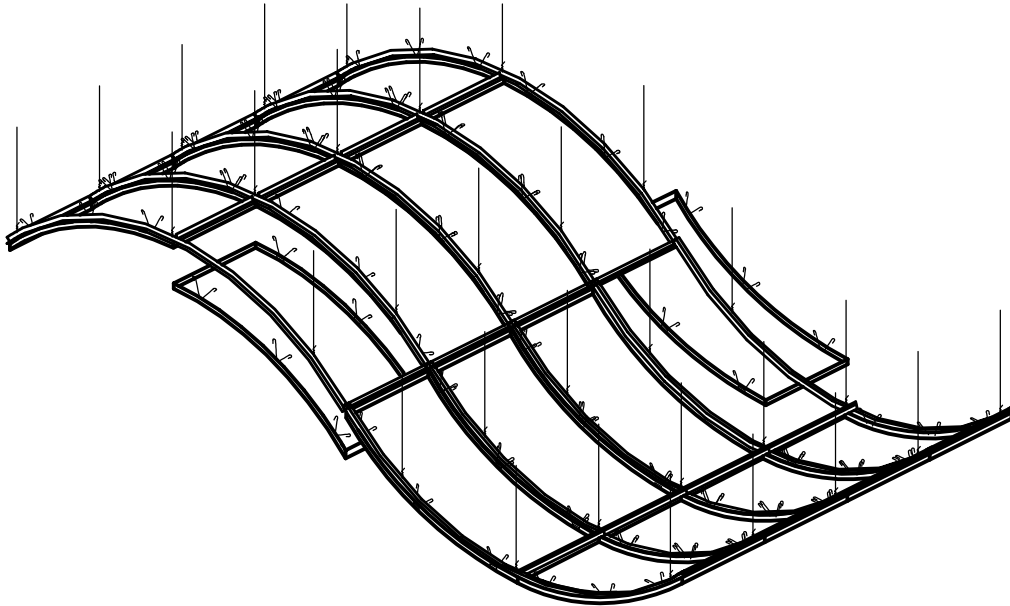

- Description:** Concealed torsion spring mounting system creates a clean monolithic appearance. Butt joint and reveal joints available, Perforated and Non-Perforated Concealed heavy-duty tee bar grid system supports each panel. Each individual panel can be removed without disturbing adjacent panels.
- Application:** Ceiling provided for interior installation. (See AC-410EXT for exterior application)
- Material:** Panels are available in aluminum, steel or stainless steel.
- Finishes:** Anodized, brushed and bright finish. Painted powder coat colors. Reference Options tab for available finishes.
- Standard Sizes:** 24" x 24", 24" x 48", 30" x 30", 36" x 36", 36" x 60", 30' x 72", 30" x 96" and 48" x 48". Custom sized and shaped panels also available.
- Fire Rating:** Class A
- Acoustics:** NCR rating of .70 to .100 can be achieved by selecting correct perforation pattern and acoustical backing.
- Perforation:** Reference Options Tab for Patterns, consult manufacturer for acoustical values
- Recycled content:** Aluminum 60% · Steel 33% · Stainless Steel 69%

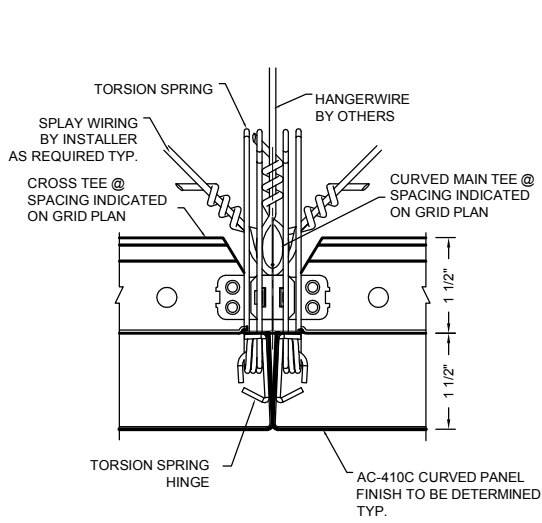

**1** PANEL JOINT DETAIL  
AC-410C-PJ1

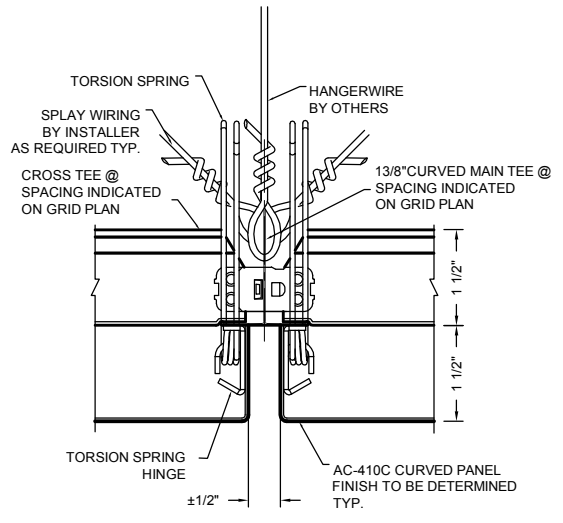

**2** PANEL JOINT DETAIL  
AC-410C-PJ2

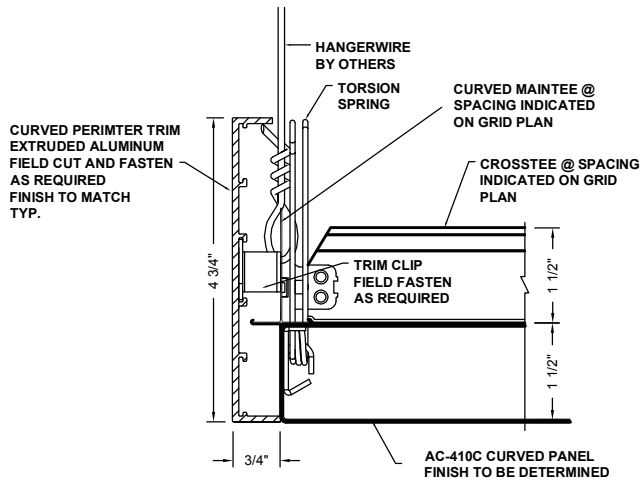

**3** PERIMETER DETAIL  
AC-410C-P1

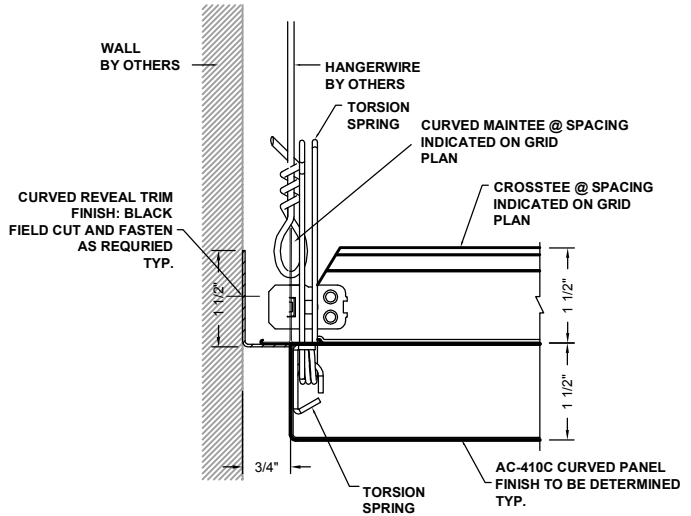

**4** PERIMETER DETAIL  
AC-410C-P2

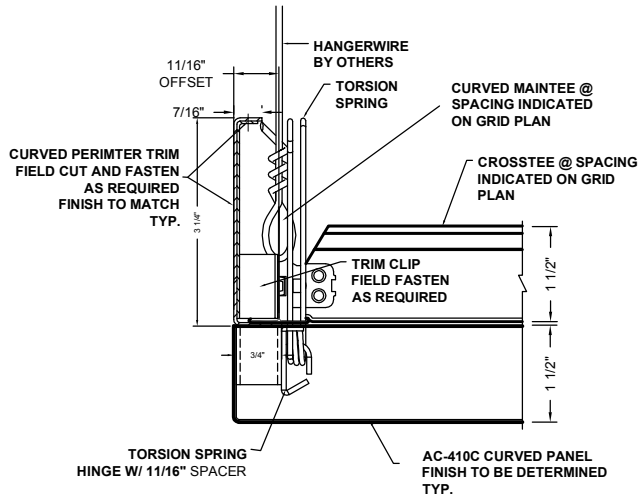

**5** PERIMETER DETAIL  
AC-410C-P3

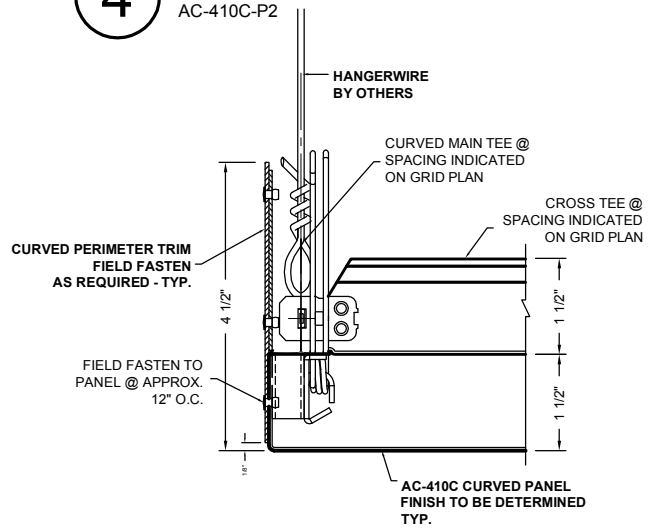

**6** PERIMETER DETAIL  
AC-410C-P4

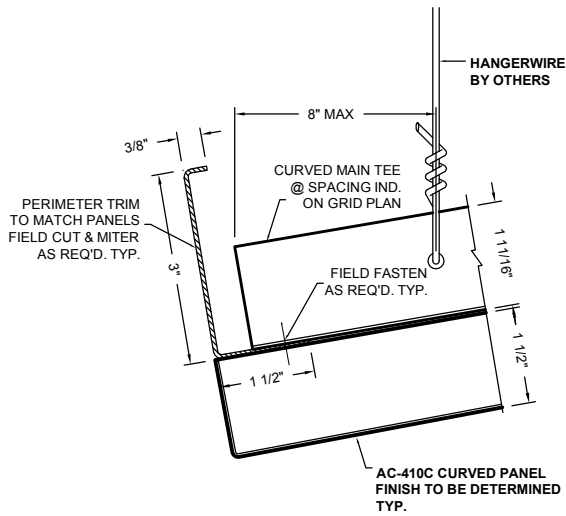

**1** PERIMETER DETAIL  
AC-410C-P5

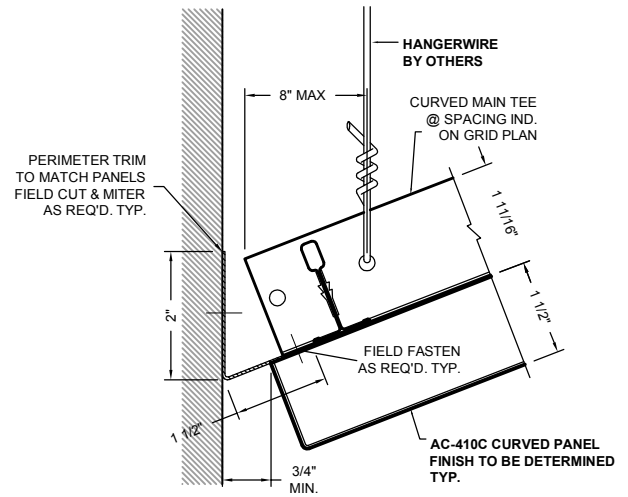

**2** PERIMETER DETAIL  
AC-410C-P6

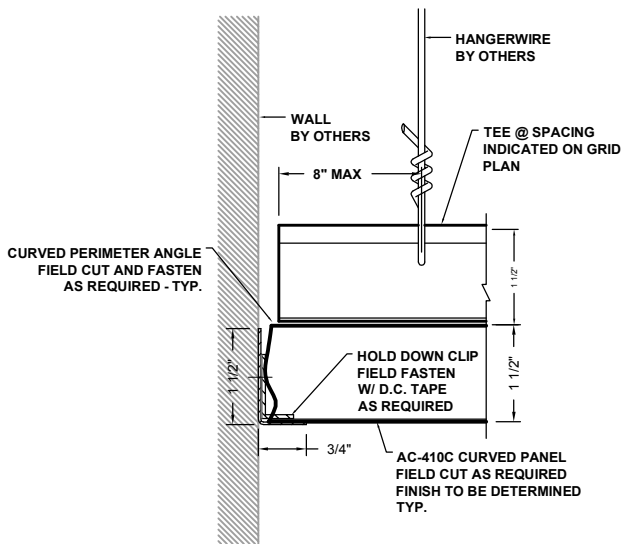

**3** PERIMETER DETAIL  
AC-410C-PFC1

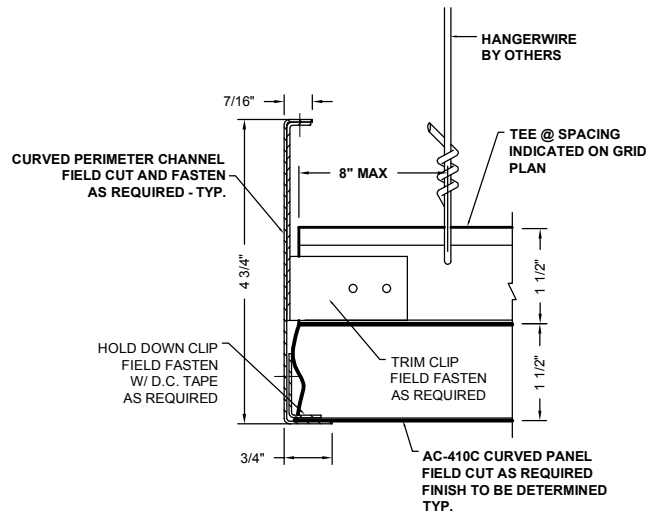

**4** PERIMETER DETAIL  
AC-410C-PFC2

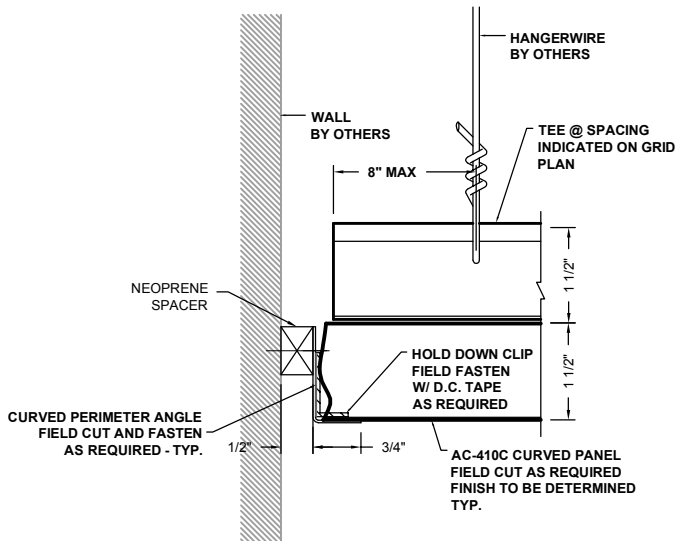

**5** PERIMETER DETAIL  
AC-410C-PFC3

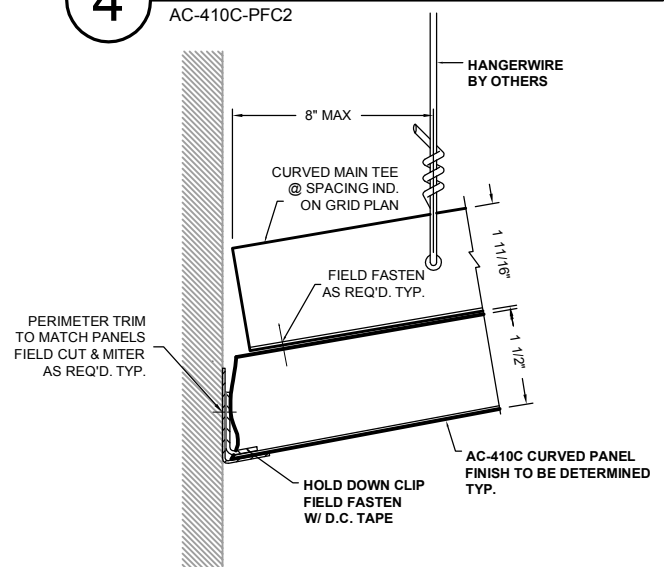

**6** PERIMETER DETAIL  
AC-410C-PFC4