

accent[®]

CEILING AND WALLS

A DIVISION OF ADAMS CAMPBELL COMPANY
ISO 9001: 2000 CERTIFIED

LAY-IN FLAT ENVIROWOOD CEILING SYSTEM (AC-130F)

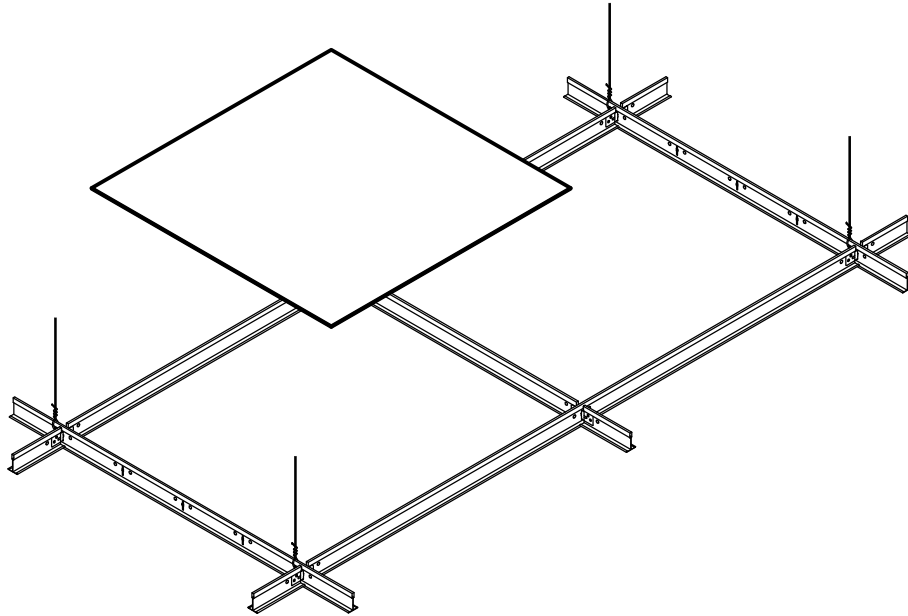

- Description:** Economical simulated wood grain finish lay-in ceiling system, Perforated or Non-Perforated, Exposed standard grid system. Flat sheet panel (no upturned edges). Efficient and quick installation. Panel drops into ceiling grid and secured in place with snap-on hold down clip.
- Application:** Ceiling provided for interior installation. (See AC-130C for curved application)
- Material:** Aluminum / Vinyl Veneer
- Finishes:** Standard simulated wood grain veneers include Maple, Oak and Cherry. Reference Options tab for additional available finishes.
- Standard Sizes:** 24" x 24", 24" x 48", Custom sized panels also available.
- Fire Rating:** Class A
- Acoustics:** NCR rating of .70 to .100 can be achieved by selecting correct perforation pattern and acoustical backing.
- Perforation:** Reference Options Tab for Patterns, consult manufacturer for acoustical values
- Recycled content:** Aluminum 60% · Steel 33% · Stainless Steel 69%

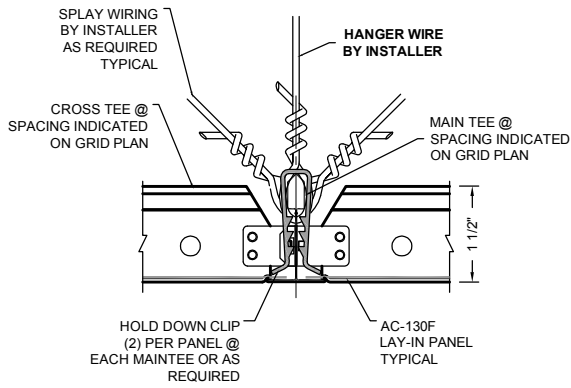

1 PANEL JOINT DETAIL
AC-130F-PJ1

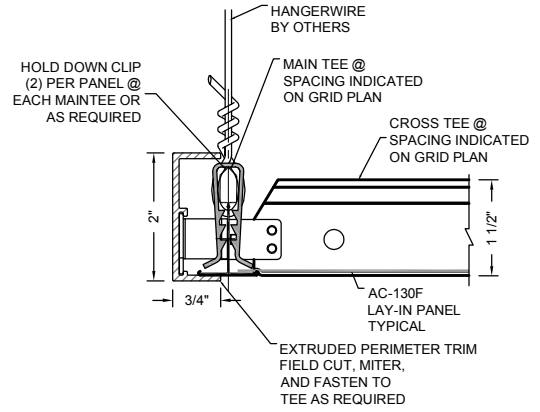

2 PERIMETER DETAIL
AC-130F-P1

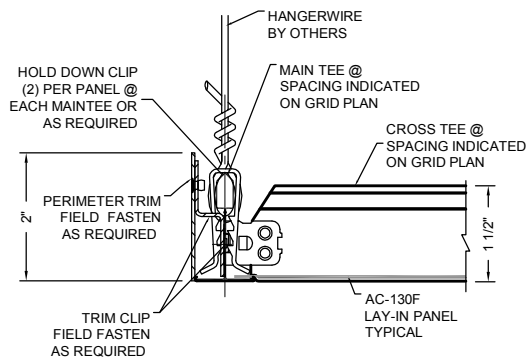

3 PERIMETER DETAIL
AC-130F-P2

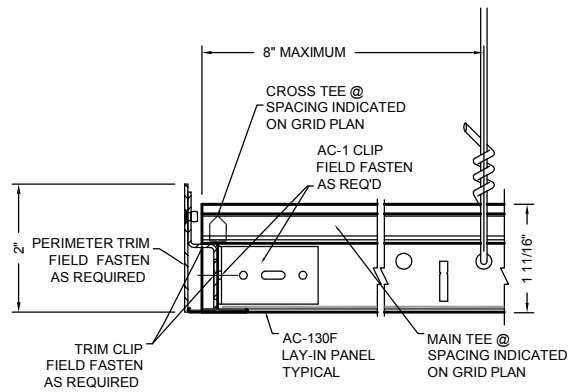

4 PERIMETER DETAIL
AC-130F-P3

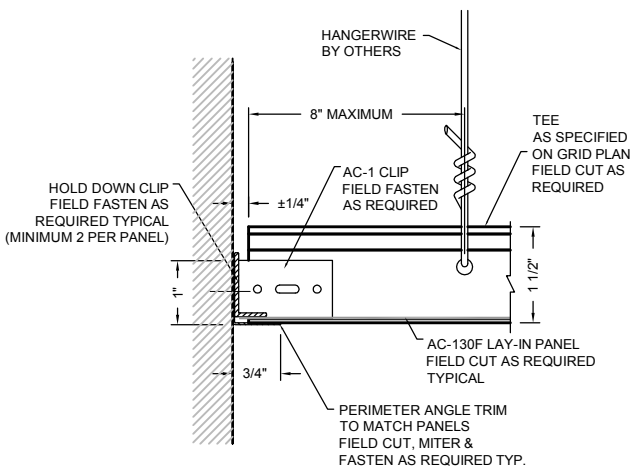

5 PERIMETER DETAIL
AC-130F-PFC1

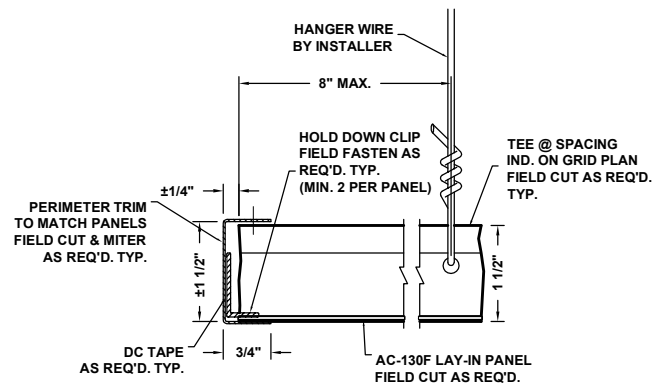

6 PERIMETER DETAIL
AC-130F-PFC2